

4. Vibration Testing



SWANSEA INSTITUTE
ATHROFA ABERTAWE

To determine the effects of vibration on High Torque Fastener Systems formed helix and mating fastener.

Test Equipment

The research programme between Swansea Institute of Higher Education and High Torque Fastener Systems has been enhanced by the acquisition of a £30,000 Derritron VP30 Electrodynamic vibration test rig specifically brought into the materials laboratory for the testing of the HTFS product.

This equipment gives the capability of examining how the fastener behaves when subjected to various vibration conditions with the aim of mimicking physical vibration conditions encountered out in the field but under laboratory conditions.

Initially the institute has focused on Fixed Sine Vibration at a single frequency where the vibration table will oscillate up and down at the same rate in the form of a sine wave. Beyond this the equipment also has the capability of performing Swept Sine Vibration and Random Vibration where varying frequencies between 0.1Hz and 6553Hz can be used in 0.1Hz increments. It can also be used to test more specific situations.



Derritron TW1500 Amplifier

Primarily designed as direct coupled matching drive sources for Derritron electromagnetic vibrators, these amplifiers give high efficiency operation over a wide frequency range.



Derritron VP30 Vibrator

Derritron vibrators are designed for continuous operation under sine, random noise and shock conditions.



Swept Sine Controller

PSC programmable swept sine controller.

4. Vibration Testing



SWANSEA INSTITUTE
ATHROFA ABERTAW

Fastener Specification

A number of test sections similar in design, with a range of bends and folds have been used during these tests. Each of the panels has the High Torque helix formed in different positions allowing for variations in the vibration trial. The fasteners used during tests are production supplied parts and drawings of both fasteners and test panels are shown below.

Customer: HIGH TORQUE	Customer Ref. Ø6x16-HXFLG	Material Size. Ø6 x 1.6mm MATERIAL	Mat. Quality. BS3111/9/2 OR EQUIVALENT	Heat Treatment HARDEN TEMPER GRADE 8.8	Finish. BLACK WX-100 (S436)	R.D No. 10184-H3	Issue 1
<i>Customer Copy</i>						Enquiry No.	Issue
				ISS.	DATE	WAS	APP.
				MODIFICATIONS			
				HIGH TORQUE THREAD 3.2mm PITCH			
This filing is only to be used with appropriate High Torque helix form.				Tooling, tooling inserts and fasteners described are elements of the High Torque Fastener System design, and is protected by patent. All rights reserved.			
HIGH TORQUE FASTENER SYSTEMS LTD TECHNIUM 2, KINGS ROAD SWANSEA, SA1 8PJ TEL: +44 (0) 1792 485561 FAX: +44 (0) 1792 485564				WORLD WIDE PATENT PCT No. 0680567 U.K. PAT. 2274497 U.S.A. PAT. 5636956		DO NOT SCALE Drawn: CSP Date: 14/12/00 Checked: CSP	
ISS.				DATE			
WAS				APP.			
MODIFICATIONS							

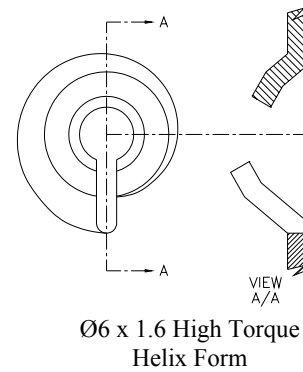

Ø6 x 1.6mm fastener specification drawing

Customer: HIGH TORQUE	Customer Ref. Ø8x16-HXFLG	Material Size. Ø8 x 2.0mm MATERIAL	Mat. Quality. BS3111/9/2 OR EQUIVALENT	Heat Treatment HARDEN / TEMPER GRADE 8.8	Finish. BLACK WX-100 (S436)	R.D No. 10325-H3	Issue 1
<i>Customer Copy</i>						Enquiry No.	Issue
				ISS.	DATE	WAS	APP.
				MODIFICATIONS			
				High Torque Thread 4.0mm Pitch			
This filing is only to be used with appropriate High Torque helix form.				Tooling, tooling inserts and fasteners described are elements of the High Torque Fastener System design, and is protected by patent. All rights reserved.			
HIGH TORQUE FASTENER SYSTEMS LTD TECHNIUM 2, KINGS ROAD SWANSEA, SA1 8PJ TEL: +44 (0) 1792 485561 FAX: +44 (0) 1792 485564				WORLD WIDE PATENT PCT No. 0680567 U.K. PAT. 2274497 U.S.A. PAT. 5636956		DO NOT SCALE Drawn: PAD Date: 12/12/02 Checked: PAD	
ISS.				DATE			
WAS				APP.			
MODIFICATIONS							

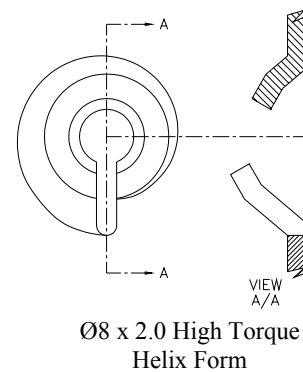

Ø8 x 2.0mm fastener specification drawing

4. Vibration Testing



Panel Designs

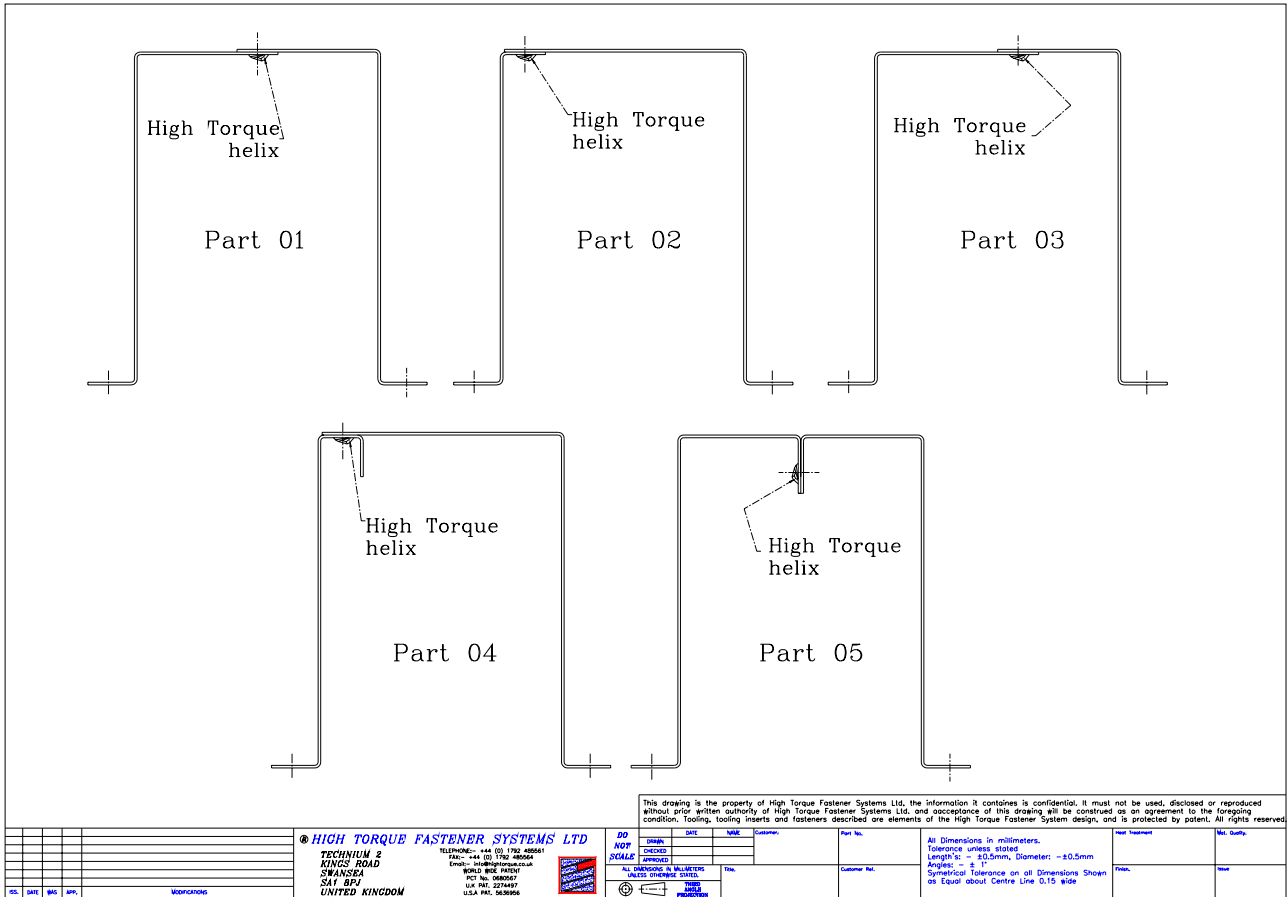

The above drawing (shows panels 01, 02, 03, 04 and 05), the deviations in panel design and positions of the High Torque formed helix, allowed for a variety of vibration test criteria when attached to the VP30 vibration equipment.

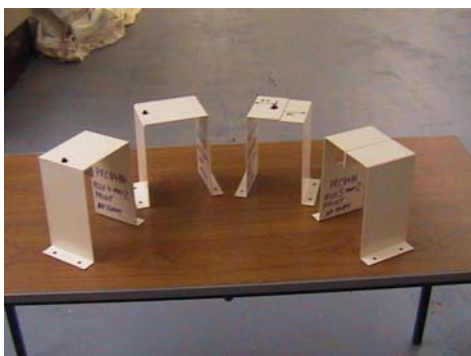

Figure 1 with some of the assemblies as indicated above, ready to undergo the vibration test cycle



Figure 2 showing component attached to VP30 Vibrator prior to testing

4. Vibration Testing



Test procedure

As previously noted this test is to evaluate the vibration characteristics of the High Torque Fastener Systems in both of the following screw diameters and panel thickness.

- Ø6mm fastener in 1.6mm thick material
- Ø8mm fastener in 2.0mm thick material

These were inserted into the various panel designs, and attached to the shaker via the manufactured face plate.

Each design variation was vibrated over a period of 12 hours, and tested at the following frequency ranges and displacements.

- 16Hz to 60Hz with a displacement of 1.5mm
- 60Hz to 200Hz with a displacement of 4mm

The fastener and panels for all design layouts were assembled using the following torque settings: -

Ø6mm fastener in 1.6mm thick material

- 4.0Nm (minimum recommended tightening torque)
- 8.0Nm (maximum recommended tightening torque)

Ø8mm fastener in 2.0mm thick material

- 16.0Nm (minimum recommended tightening torque)
- 22.0Nm (maximum recommended tightening torque)

Test duration (machine time) – 10 days per screw and plate size
(5 designs x 12 hours x 2 torque settings x 2 vibration frequencies).

The time displacement from bottom to top of both frequency range tests is set at approximately 5 minutes as indicated in the graphs below.

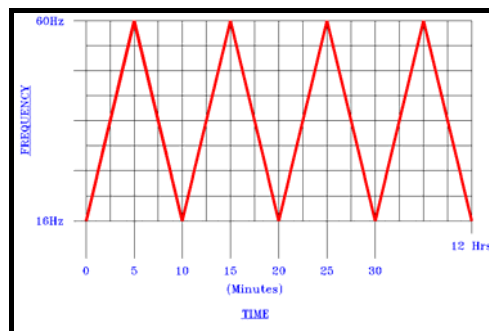

Frequency range 1 – Displacement 1.5mm

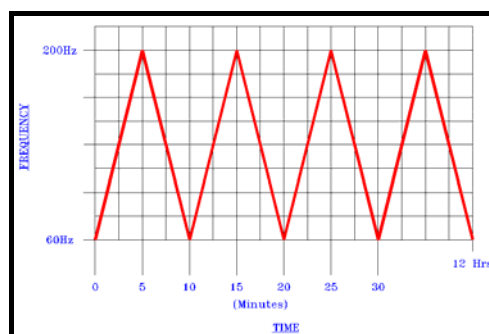

Frequency range 2 – Displacement 4mm

4. Vibration Testing



Observations

Assembly torque figures shown in the tabulated data were taken from a Proto dial torque wrench with slave pointer, after the 12 hour period observations were made of the assemblies, and the information tabulated: -

Diameter – 6mm

- i) 4.0Nm – None of the assembled components had shown any evidence of losing their integrity whatsoever, with the joint maintaining its assembly torque of 4.0Nm.
- ii) 8.0Nm – None of the assembled components had shown any evidence of losing their integrity whatsoever, with the joint maintaining its assembly torque of 8.0Nm.

Diameter – 8mm

- iii) 16.0Nm – None of the assembled components had any evidence of loosening, the only observation being design layout (part 02) indicated a minor twisting of the assembled plates.
- iv) 22.0Nm – None of the assembled components had any evidence of loosening, the only observation being design layout (part 02) indicated a minor twisting of the assembled plates.

Design Layout	Thread Diameter (mm)	Material Thickness (mm)	Assembly Torque (Nm)	Break loose torque before test (Nm)	Break loose torque after test (Nm)	Assembly torque after test
01	6	1.6	4.0	1.6	1.6	No Change from initial assembly torque.
			8.0	3.7	3.7	
	8	2.0	16.0	7.0	8.5	
			22.0	9.0	10.0	
02	6	1.6	4.0	1.6	1.6	
			8.0	3.7	3.7	
	8	2.0	16.0	5.0	5.5	
			22.0	11.0	11.5	
03	6	1.6	4.0	1.6	1.6	
			8.0	3.7	3.7	
	8	2.0	16.0	7.0	7.5	
			22.0	10.5	11.0	
04	6	1.6	4.0	1.6	1.6	
			8.0	3.7	3.7	
	8	2.0	16.0	5.5	6.5	
			22.0	10.5	11.0	
05	6	1.6	4.0	1.6	1.6	
			8.0	3.7	3.7	
	8	2.0	16.0	6.0	6.5	
			22.0	10.0	10.5	

4. Vibration Testing



Conclusions

Much work has previously been carried out to explain why the High Torque Fastener System product is able to withstand vibration, unlike a conventional fastener where the bolt is put under tension and stretched which requires extreme torque loadings to achieve, the High Torque fastening system achieves the same results but uses only a fraction of the assembly torque loading. The High Torque product does not follow the same principal as a conventional fastener; it's the helical form that is primarily put under tensile loading, thus reducing the stress in the bolt. The locking engagement in the fastener arises from a relatively small deflection in the helical form, requiring less torque to achieve sufficient securing tension.

With the small amount of deflection needed to achieve lock up, the helical form tries to re-set itself to its original formed position. This flexibility acts as a natural spring, with the added benefits of helping prevent the fastener working loose in application where vibration is present. This eliminates the need for any shake proof washers or patch technology to achieve similar results as would have previously been required. The results obtained during these tests on the various panel designs, goes some way in highlighting the integral characteristics within the High Torque design to withstand vibration.

These test results are consistent with similar tests carried out by Swansea Institute along with field trials carried out by customers of High Torque Fastener Systems. From these tests we can conclude that the High Torque Fastener System does withstand extreme vibration conditions for the size tested and will not work loose provided that the recommended assembly guidelines are adhered to.