

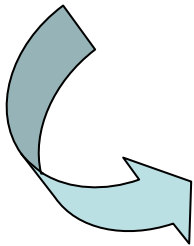

## THE EXPANSION CLIP

Suitable Applications from 2-3mm panel thickness

Incorporating the High Torque Fastener Systems enhanced geometric thread design.

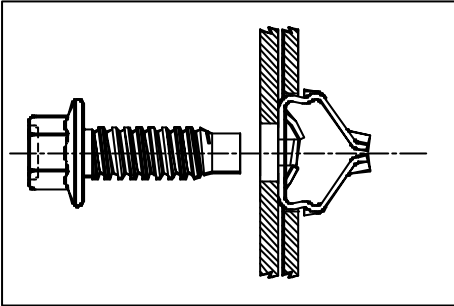

Extreme Strength

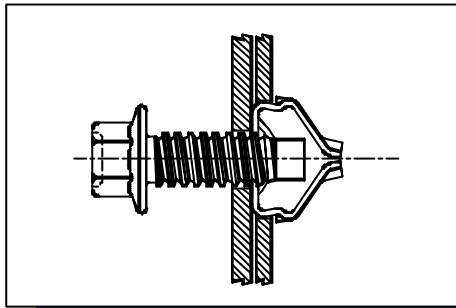

Easy Insertion

High Pull out Load

Prevailing Torque

Vibration Resistant

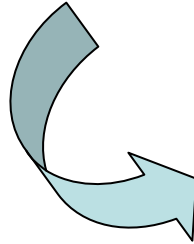

No Special Insertion Equipment Required

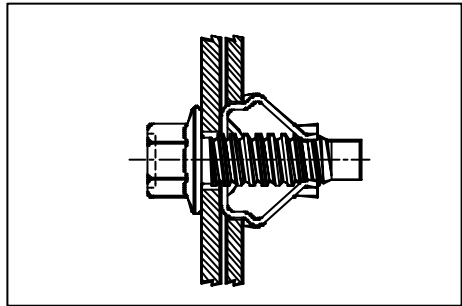

### KEY ATTRIBUTES

Formed radii to assist insertion

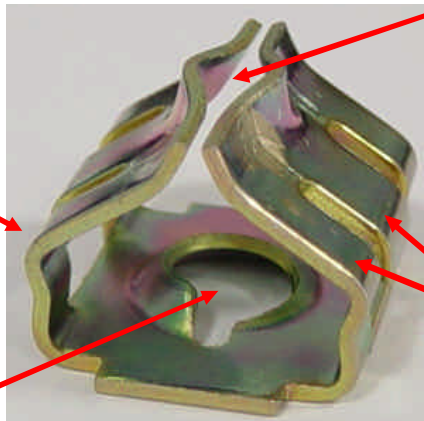

Prevailing torque feature, applies even pressure on external fastener thread

Expansion legs and formed knuckles lock into material when inserted

Ø8 High Torque Helix

# HIGH TORQUE FASTENER SYSTEMS – *The Expansion*



## DIMENSION DETAILS

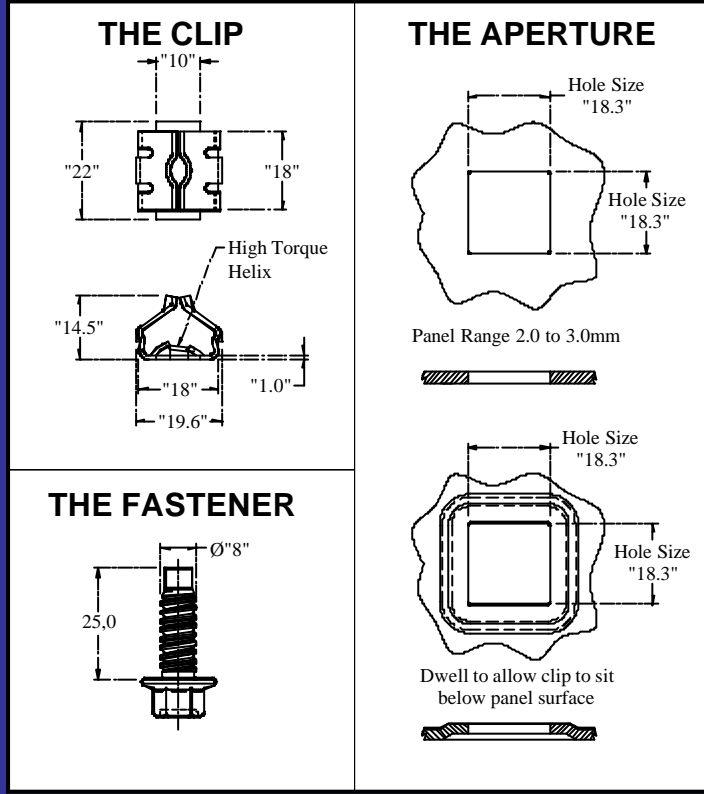

## PERFORMANCE DATA

### MAX. TIGHTENING TORQUE

Newton Meters		
Min	Max	Mean
27.5	35	30.8

### LOAD TEST

Kilograms		
Min	Max	Mean
200	290	255

### CLAMP LOAD

Newtons		
Min	Max	Mean
5874	5837	5776

## SUITABLE APPLICATIONS



**HIGH TORQUE FASTENER SYSTEMS – Technium 2, Kings Road, Swansea, SA1 8PJ**  
 Telephone: +44 (0)1792 485561      FAX +44 (0)1792 485564  
[www.hightorque.co.uk](http://www.hightorque.co.uk)      [info@hightorque.co.uk](mailto:info@hightorque.co.uk)